

Auszug aus Getriebetechnik II, 6. Vorlesung: Wattscher Lenker



6. Vorlesung Getriebetechnik II

Institut für Getriebetechnik und Maschinendynamik, RWTH Aachen



IGM
Direktor: Univ.-Prof. Dr.-Ing. B. Corves
RWTH AACHEN
RHEINISCH-WESTFÄLISCHE TECHNISCHE HOCHSCHULE AACHEN

Symmetrischer Wattscher Lenker

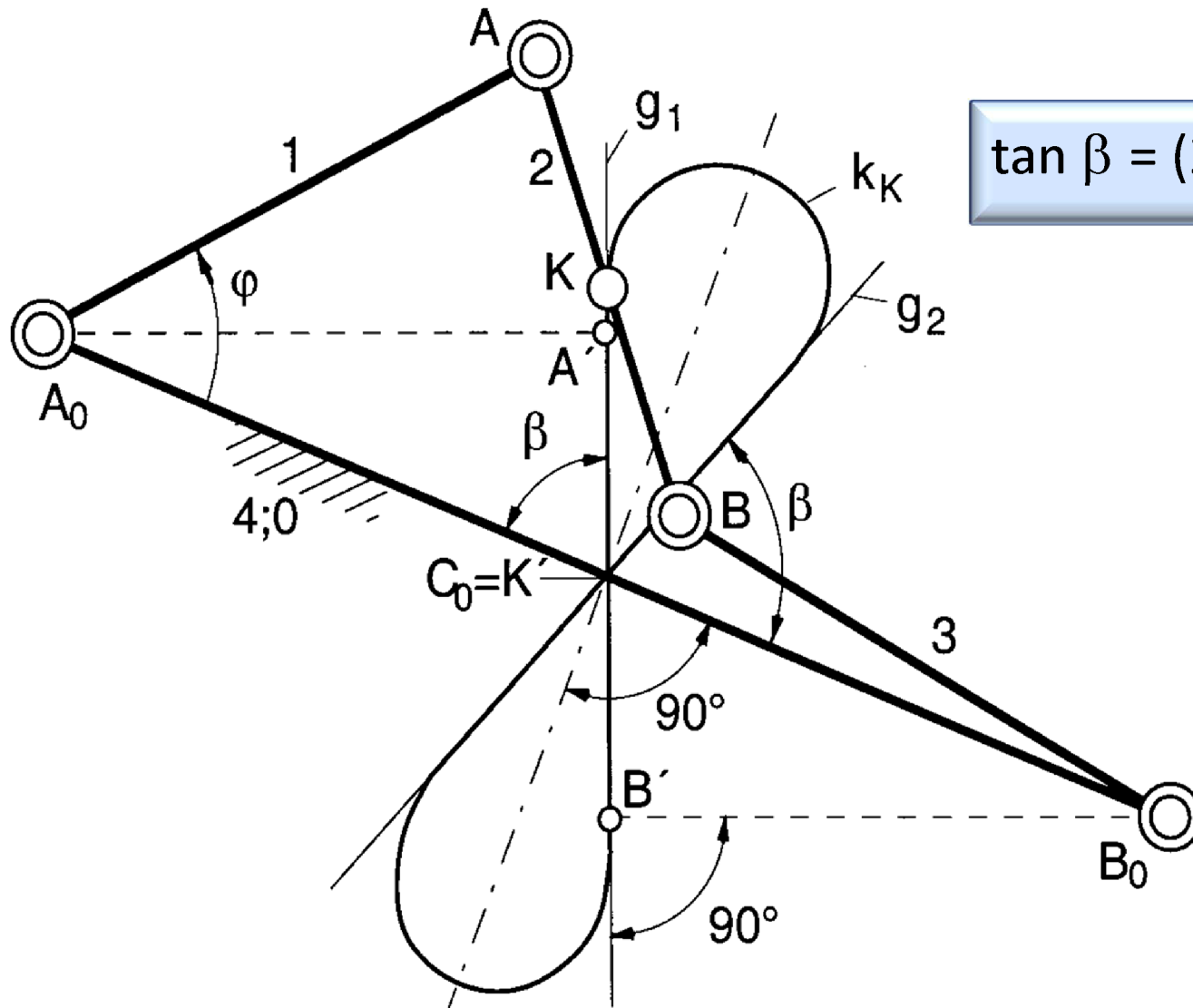

$$\tan \beta = (2 l_1) / l_2$$



Wattscher Lenker und Evans-Lenker

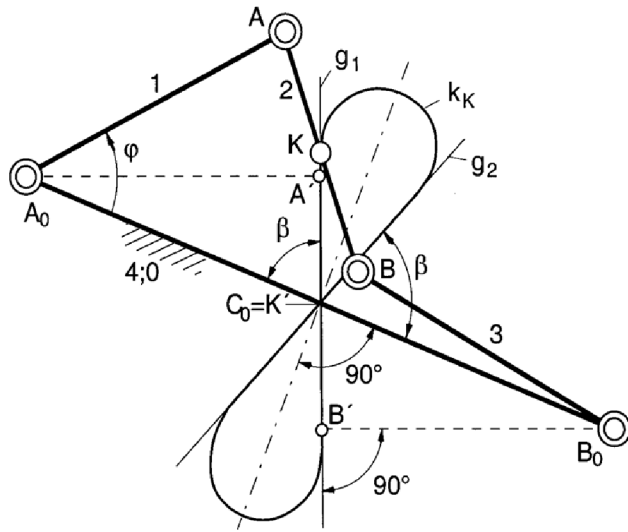

$$\tan \beta = (2 l_1) / l_2$$

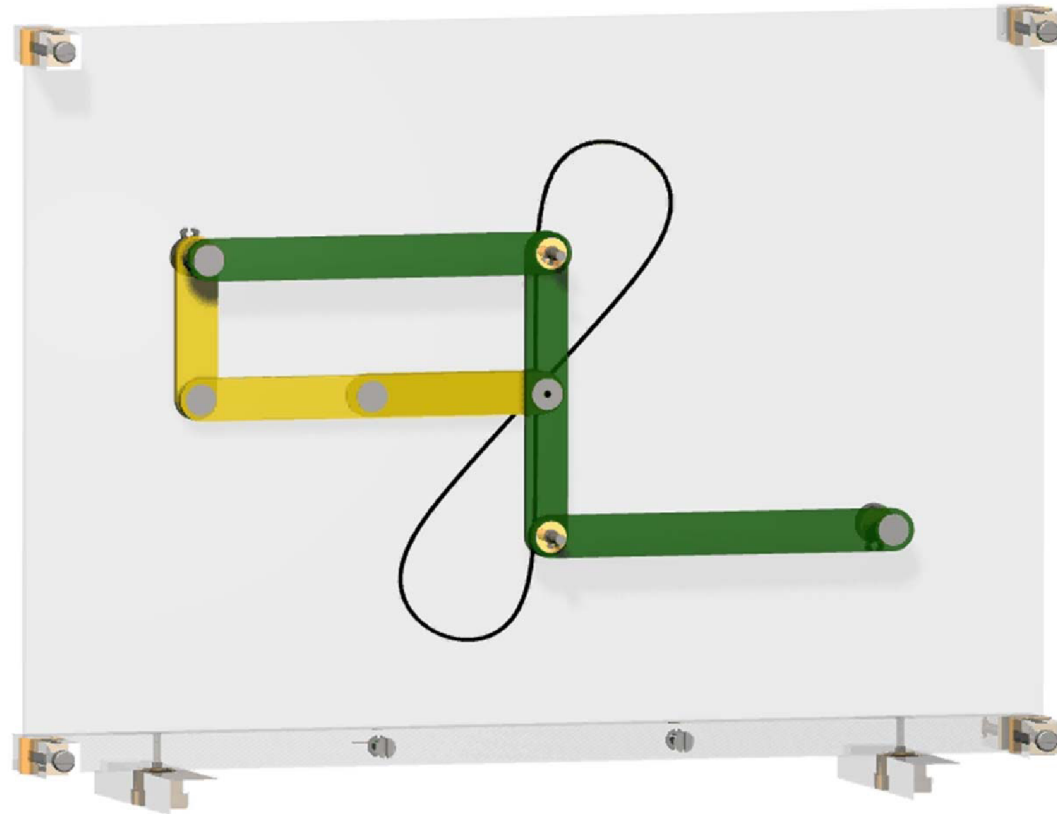
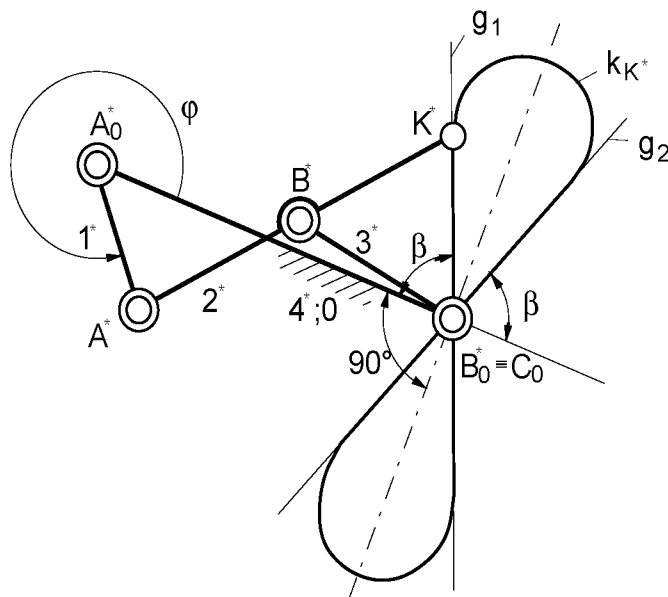

Anwendungsbeispiele für Wattschen Lenker

Kolbenführung

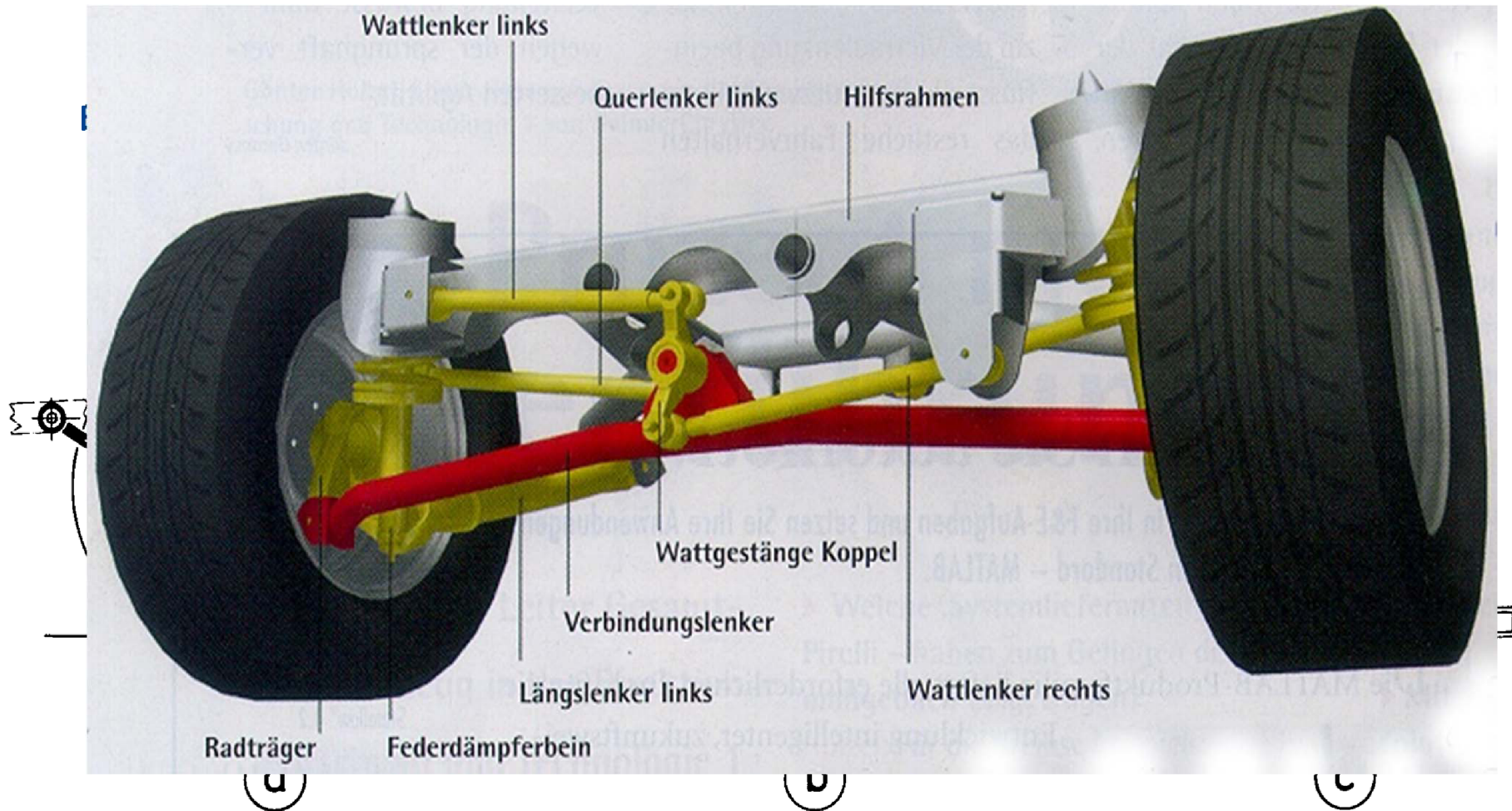

Anwendungsbeispiel: Fahrwerk Opel Astra

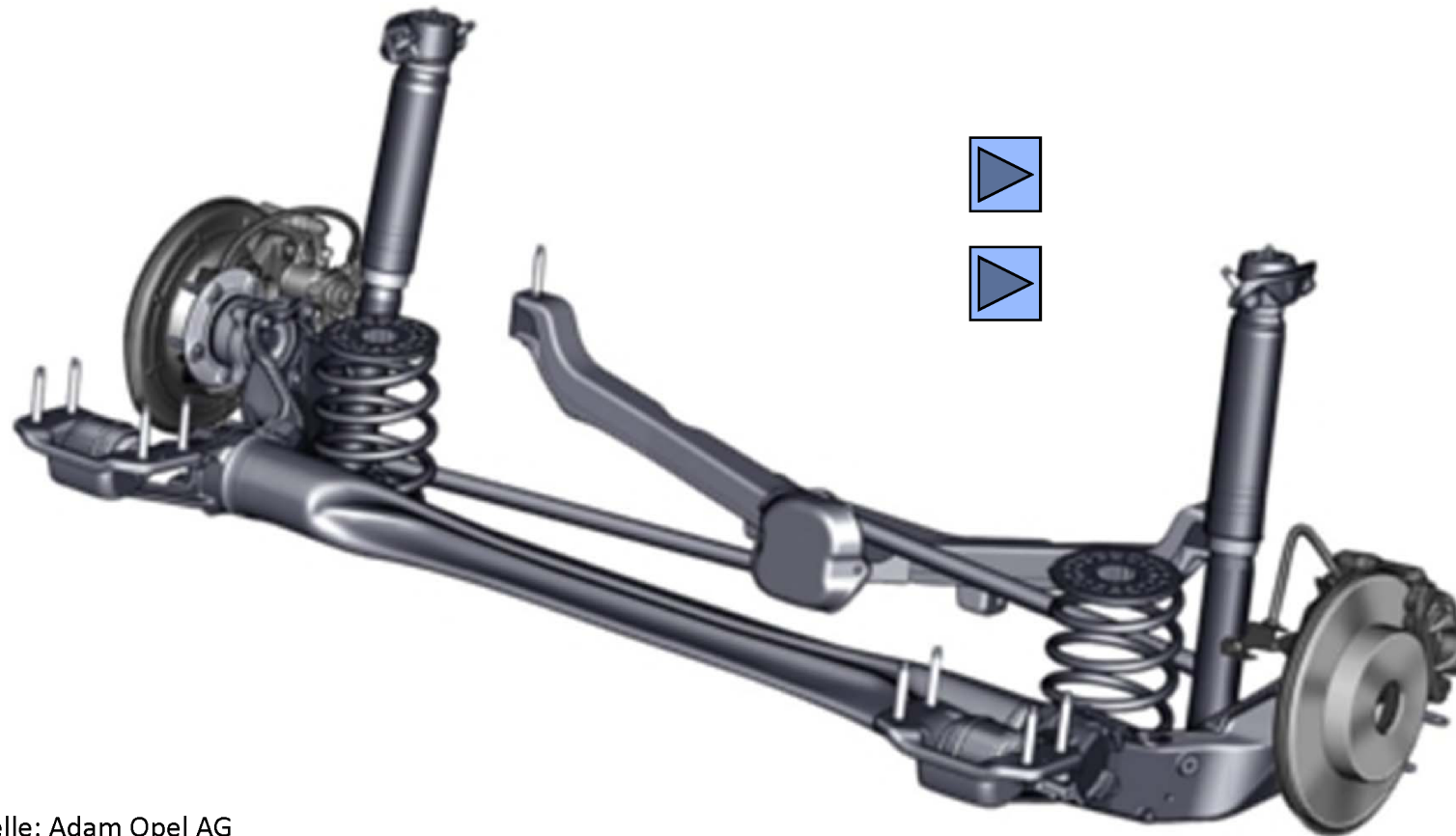

Quelle: Adam Opel AG

Schwingungsprüfstand für Kfz-Achsen und Karosserien

